



Devices for switching and control  
***Conteo***



[WWW.OEZ.COM](http://WWW.OEZ.COM)



## MOTOR STARTERS SM



### ■ Basic function

Switching and protection of motors up to 25 A. Protection against short-circuit and protection against overload. The device responds to phase failure.

The device is provided with the compensation for ambient temperature effect.

SM1E devices fully substitute SM1 devices. It is not possible to combine SM1 and SM1E accessories.

### Motor starters

Instantaneous overcurrent release is fixed to  $12x I_n$ .

Appropriate for three-phase motors of output <sup>2)</sup>	Rated current	Type	Product code	Setting range of the thermal overcurrent release	Rated short-circuit ultimate breaking capacity <sup>1)</sup>	Weight	Package
$P_n$ [kW]	$I_n$ [A]			[A]	$I_{cu}$ [kA]	m [kg]	[pcs]
0.02	0.16	<b>SM1E-0,16</b>	39257	0.1 ÷ 0.16	50	0.252	1
0.06	0.25	<b>SM1E-0,25</b>	39258	0.16 ÷ 0.25	50	0.252	1
0.09	0.4	<b>SM1E-0,4</b>	39259	0.25 ÷ 0.4	50	0.252	1
0.12	0.63	<b>SM1E-0,63</b>	39260	0.4 ÷ 0.63	50	0.252	1
0.25	1	<b>SM1E-1</b>	39261	0.63 ÷ 1	50	0.252	1
0.55	1.6	<b>SM1E-1,6</b>	39262	1 ÷ 1.6	50	0.252	1
1.1	2.5	<b>SM1E-2,5</b>	39263	1.6 ÷ 2.5	50	0.252	1
1.5	4	<b>SM1E-4</b>	39264	2.5 ÷ 4	50	0.252	1
2.5	6.3	<b>SM1E-6,3</b>	39265	4 ÷ 6.3	50	0.252	1
4	10	<b>SM1E-10</b>	39266	6.3 ÷ 10	6	0.252	1
7.5	16	<b>SM1E-16</b>	39267	10 ÷ 16	4	0.252	1
9	20	<b>SM1E-20</b>	39268	16 ÷ 20	4	0.252	1
11	25	<b>SM1E-25</b>	39269	20 ÷ 25	4	0.252	1

<sup>1)</sup>  $U_e = 400$  V a.c.

<sup>2)</sup> Informative value for 4-pole motors at 400 V a.c., 50 Hz. Specific rated data and the data about start of the protected motor are decisive for selection.

### Motor starters in insulating box with degree of protection IP55 (the package contains motor starter and insulating box)

Instantaneous overcurrent release is fixed to  $12x I_n$ .

Appropriate for three-phase motors of output <sup>2)</sup>	Rated current	Type	Product code	Setting range of the thermal overcurrent release	Rated short-circuit ultimate breaking capacity <sup>1)</sup>	Weight	Package
$P_n$ [kW]	$I_n$ [A]			[A]	$I_{cu}$ [kA]	m [kg]	[pcs]
0.55	1.6	<b>SM1E-1,6-IP55</b>	39311	1 ÷ 1.6	50	0.502	1
1.1	2.5	<b>SM1E-2,5-IP55</b>	39312	1.6 ÷ 2.5	50	0.502	1
1.5	4	<b>SM1E-4-IP55</b>	39313	2.5 ÷ 4	50	0.502	1
2.5	6.3	<b>SM1E-6,3-IP55</b>	39314	4 ÷ 6.3	50	0.502	1
4	10	<b>SM1E-10-IP55</b>	39315	6.3 ÷ 10	6	0.502	1

<sup>1)</sup>  $U_e = 400$  V a.c.

<sup>2)</sup> Informative value for 4-pole motors at 400 V a.c., 50 Hz. Specific rated data and the data about start of the protected motor are decisive for selection.

### Accessories

Switches	<b>PS-SM1E</b>	pg. D18
Shunt trips and undervoltage releases	<b>SV-SM1E, SP-SM1E</b>	pg. D19
Interconnecting busbars	<b>G-3L-MS</b>	pg. D20
Power supply units	<b>ESB-G-MS2</b>	pg. D20
Insulating boxes and accessories	<b>OD-SM1E</b>	pg. D21

### Parameters

Size	1	
Type	<b>SM1E</b>	
Standards	EN 60947-2, EN 60947-4-1	
Approval marks		
Number of poles	3	
Rated current	$I_n$	0.16 ÷ 25 A
Rated operating voltage	$U_e$	690 V a.c.
Rated frequency	$f_n$	50 Hz
Mechanical endurance	100 000 cycles	
Electrical endurance (AC-3)	100 000 cycles	
Max. switching frequency	30 cycles/hr	

# MOTOR STARTERS SM



## Specification

Size	1	
Type	SM1E	
Rated pulse withstand voltage (1.2/50 ms)	$U_{imp}$	6 kV
Mounting	(EN 60715) „U“ rail TH35 by means of screws on the plate	
Degree of protection	the device itself	
	IP20	
	the device in insulating box	
	max. IP55	
Power losses (1 pole)	2 ÷ 2.5 W	
Operating conditions	ambient temperature	
	-25 ÷ 60 °C	
	temperature compensation range	
	-5 ÷ 40 °C	
Working position	preferably vertical	
Seismic resistance (5 ÷ 150 Hz)	5 g	
Surge resistance	20 g	

## Short-circuit release and rated short-circuit ultimate breaking capacity

Type	Rated current $I_n$	Short-circuit release	Rated short-circuit ultimate breaking capacity $I_{cu}$				Fuse <sup>1)</sup>			
			230 V	400 V	500 V	690 V	230 V	400 V	$I_{cc} > I_{cu}$	500 V
SM1E-0.16	0.16 A	2 A	50 kA	50 kA	50 kA	50 kA	-	-	-	-
SM1E-0.25	0.25 A	3 A	50 kA	50 kA	50 kA	50 kA	-	-	-	-
SM1E-0.4	0.4 A	5 A	50 kA	50 kA	50 kA	50 kA	-	-	-	-
SM1E-0.63	0.63 A	8 A	50 kA	50 kA	50 kA	50 kA	-	-	-	-
SM1E-1	1 A	12 A	50 kA	50 kA	50 kA	50 kA	-	-	-	-
SM1E-1,6	1.6 A	20 A	50 kA	50 kA	50 kA	50 kA	-	-	-	-
SM1E-2,5	2.5 A	30 A	50 kA	50 kA	3 kA	2.5 kA	-	-	25 A	20 A
SM1E-4	4 A	48 A	50 kA	50 kA	3 kA	2.5 kA	-	-	35 A	25 A
SM1E-6,3	6.3 A	75 A	50 kA	50 kA	3 kA	2.5 kA	-	-	50 A	35 A
SM1E-10	10 A	120 A	50 kA	6 kA	3 kA	2.5 kA	-	80 A	50 A	35 A
SM1E-16	16 A	192 A	6 kA	4 kA	2.5 kA	2 kA	80 A	80 A	63 A	35 A
SM1E-20	20 A	240 A	6 kA	4 kA	2.5 kA	2 kA	80 A	80 A	63 A	50 A
SM1E-25	25 A	300 A	6 kA	4 kA	2.5 kA	2 kA	80 A	80 A	63 A	50 A

<sup>1)</sup> Max. fuse size, utilization category gG, usage when there is  $I_k > I_{cu}$  at the place of installation.

## Connection cross-sections

Size	1
Type	SM1E
Terminal type	clip terminal
Number of conductors / terminal	1. 2
Conductor (Cu)	
solid	0.75 ÷ 4 mm <sup>2</sup>
stranded	0.75 ÷ 4 mm <sup>2</sup>
Terminal screw	M4
Tool	PZ2
Torque	2 Nm

## Diagram

Motor starters SM1E

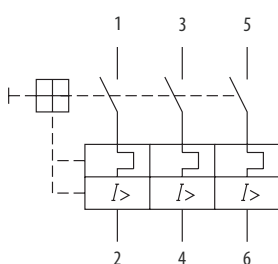

Connection of single-phase, double-phase and three-phase electric motors

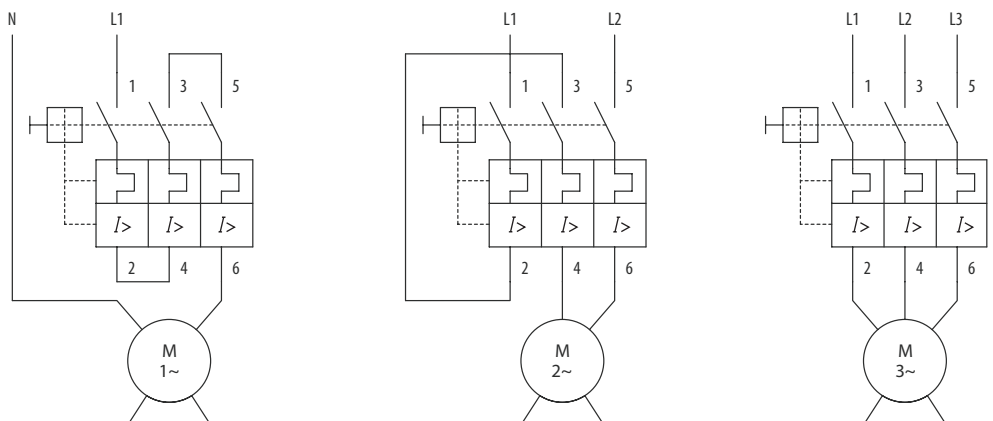

## MOTOR STARTERS SM

### Characteristics

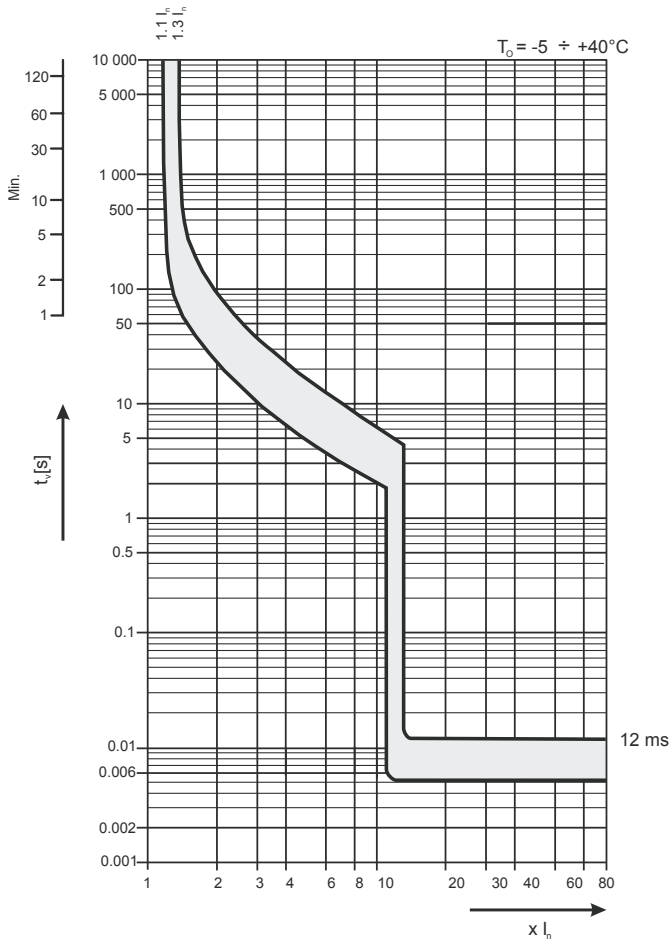

### Dimensions

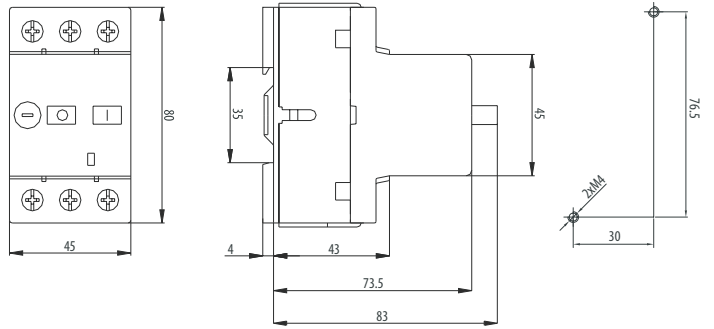

### Mounting of auxiliary switches, shunt trips and undervoltage releases

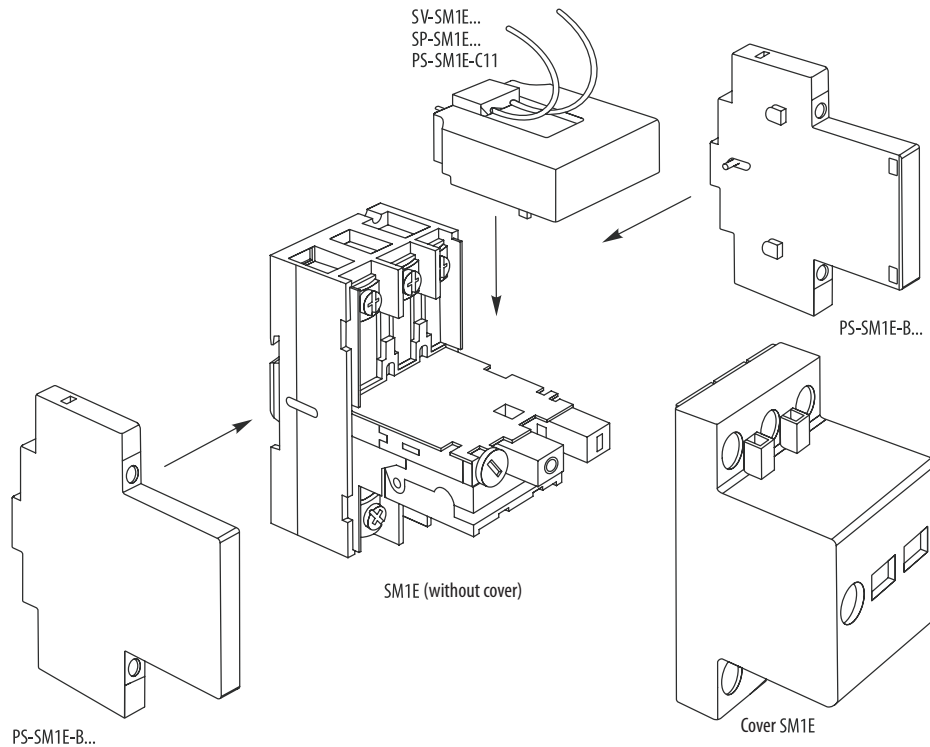

There shall be maximum one front auxiliary contact or shunt trip or undervoltage release under the motor starter cover.  
There shall be maximum one auxiliary contact for each side of device; one on the right side and the other on the left side.  
Mounting/demounting of auxiliary switches and releases shall be carried out with removed cover of motor starter.

**SWITCHES**

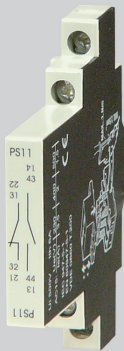

- Accessory to: SM1E.
- For signalling of the main contacts position at tripping by releases or manually, i.e. at tripping due to overload, short-circuit, by shunt trip, undervoltage release or control push-buttons.
- Max. 2 pieces of side contacts for SM1E: one on the right side and the other on the left side.
- Short-circuit protection: by miniature circuit breaker LPN  $I_n \leq 6$  A or by fuse-links PV14, PN00, PN000 etc. with  $I_n \leq 20$  A.

Arrangement of contacts NO NC <sup>1)</sup>	Design	Type	Product code	Weight m [kg]	Package [pcs]
1 1	side	<b>PS-SM1E-B11</b>	39270	0.05	1
2 0	side	<b>PS-SM1E-B20</b>	39271	0.05	1
1 1	front	<b>PS-SM1E-C11</b>	39283	0.05	1

<sup>1)</sup> NO – make contact, NC – break contact.

**Specification**

Type	PS-SM1E-B...	PS-SM1E-C...
Approval marks		
Arrangement of contacts NO NC <sup>1)</sup>	11, 20	11
Rated thermal current	$I_{th}$ 6 A	6 A
Rated operating voltage	$U_e$ max. 500 V a.c.	max. 500 V a.c.
Rated operating current		
AC-15	$I_e/U_e$ 3.5 A/230 V, 2 A/400 V, 1.5 A/500 V	3.5 A/230 V, 2 A/400 V, 1.5 A/500 V
Rated pulse withstand voltage (1.2/50 $\mu$ s)	$U_{imp}$ 6 kV	6 kV
Mechanical endurance	100 000 cycles	100 000 cycles
Electrical endurance (AC-15; 3.2 A)	100 000 cycles	100 000 cycles
Degree of protection	IP20	IP20
Mounting	on the left/right side of the motor starter	front mounting under the motor starter cover

<sup>1)</sup> NO - make contact, NC - break contact.

**Connection cross-sections**

Type	PS-SM1E-B...	PS-SM1E-C...
Terminal type	clip terminal	conductor
Number of conductors / terminal	1, 2	-
Conductor (Cu)		
solid	0.75 ÷ 2.5 mm <sup>2</sup>	-
stranded	0.75 ÷ 2.5 mm <sup>2</sup>	-
Terminal screw	M3	-
Tool	PZ2	-
Torque	1 Nm	-

**Diagram**

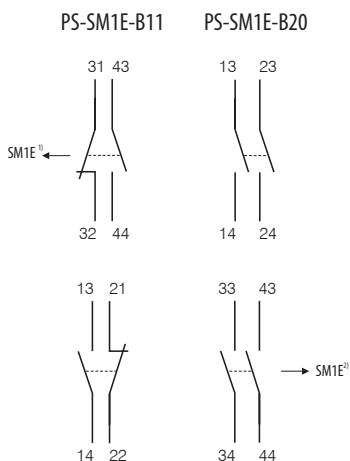

<sup>1)</sup> For mounting on motor starter from the right side.  
<sup>2)</sup> For mounting on motor starter from the left side.

**Dimensions**

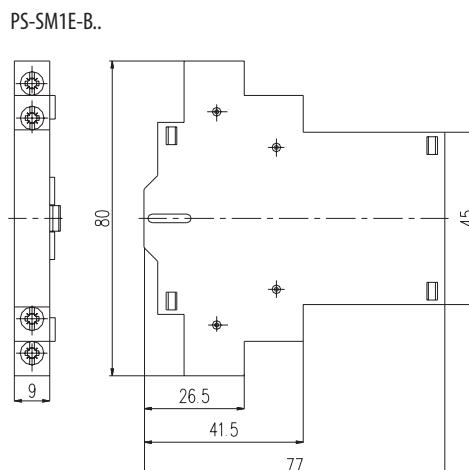

## SHUNT TRIPS AND UNDERVOLTAGE RELEASES

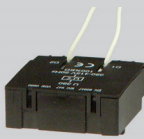
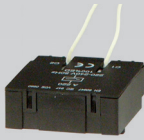

### Shunt trips

- Accessory to: SM1E.
- Excitation time is not limited.

- For tripping of the motor starter after the coil excitation by a voltage between 70% and 110%  $U_e$ .

Rated operating voltage $U_e$ [V a.c.]	Type	Product code	Weight m [kg]	Package [pcs]
24	<b>SV-SM1E-A024</b>	39277	0.06	1
220 ÷ 240	<b>SV-SM1E-A230</b>	39280	0.06	1
380 ÷ 415	<b>SV-SM1E-A400</b>	39281	0.06	1

### Undervoltage releases

- Accessory to: SM1E.
- For tripping of the motor starter at voltage loss and at voltage drop between 70% and 35%  $U_e$ .
- For tripping of the motor starter at pressing the button (break contact).

- For elimination of motor starter switching at voltage lower than 35% (the reclosing is possible at  $U \geq 85\% U_e$ ).
- For protection against motor restart following a voltage failure.

Rated operating voltage $U_e$ [V a.c.]	Type	Product code	Weight m [kg]	Package [pcs]
220 ÷ 240	<b>SP-SM1E-A230</b>	39275	0.06	1
380 ÷ 415	<b>SP-SM1E-A400</b>	39276	0.06	1

### Specification

Type		SV-SM1E...	SP-SM1E...
Approval marks			
Rated operating voltage	$U_e$	24, 230 ÷ 240, 380 ÷ 415 V a.c.	220 ÷ 240, 380 ÷ 415 V a.c.
Rated frequency	$f_n$	50 Hz	50 Hz
Starting input power		7.5 VA / 4.3 W	7.5 VA / 4.3 W
Input power		3.8 VA / 1.3 W	3.8 VA / 1.3 W
Mounting		front mounting under the motor starter cover	front mounting under the motor starter cover
Connection			
	cross-section	2x 0.35 mm <sup>2</sup>	2x 0.35 mm <sup>2</sup>
	length	230 mm	230 mm
Excitation time		unlimited	-

### Diagram

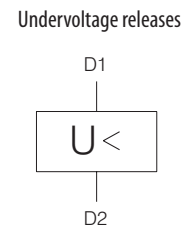
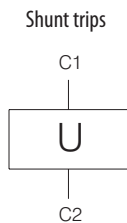

## INTERCONNECTING BUSBARS AND POWER SUPPLY UNITS

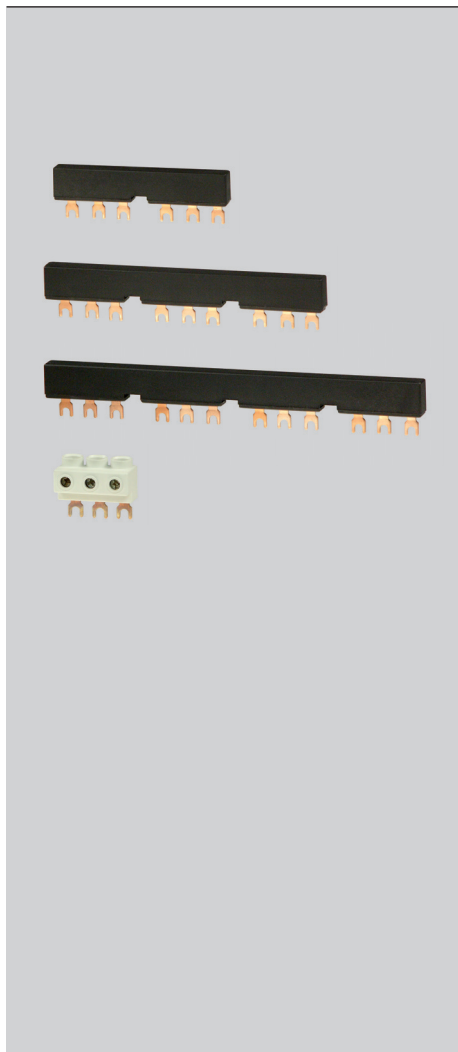

- Accessory to: SM1E.
- For quicker interconnection of 2 to 4 motor starters installed side-by-side.
- Interconnection is possible from the top and the bottom of the motor starter.
- At interconnection by rails there is a gap for one auxiliary switch PS-SM1E-B... between motor starters.
- Installed power supply unit ESB-G-MS2 allows busbar application.

### Interconnecting busbars

Type	Product code	For	Weight m [kg]	Package [pcs]
G-3L-MS-M2	182	2 motor starters	0.038	1
G-3L-MS-M3	183	3 motor starters	0.06	1
G-3L-MS-M4	184	4 motor starters	0.098	1

### Power supply unit

Type	Product code	Weight m [kg]	Package [pcs]
ESB-G-MS2	18350	0.038	1

### Specification

Type	G-3L-MS-M_
Max. loading current	63 A (power supply of end) 100 A (power supply of middle)
Degree of protection	IP20
Number of phases	3
Mounting	bottom / top

### Connection cross-sections

Type	ESB-G-MS2
Number of conductors / terminal	1
Terminal type	clamp terminal
Conductor (Cu)	
solid	6 ÷ 25 mm <sup>2</sup>
fine stranded with a socket	6 ÷ 16 mm <sup>2</sup>
Number of phases	3

### Diagram

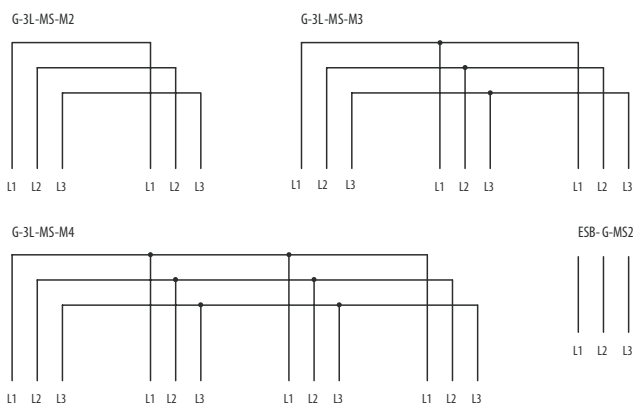

### Dimensions

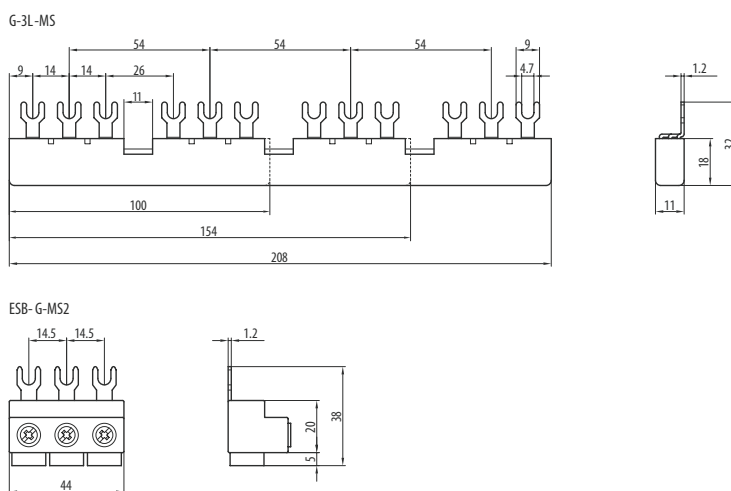

## INSULATING BOXES AND ACCESSORIES



### Insulating boxes

- Accessory to: SM1E.
- They provide degree of protection for SM1E.

- It is recommended to use plastic grommets to insulating box (are not included in the package).
- Boxes contain one PEN/PE connector; connection: conductor  $0.75 \div 4 \text{ mm}^2$ .

Type	Product code	Design	Degree of protection	Weight m [kg]	Package [pcs]
OD-SM1E-K41	39284	Wall mounting	IP41	0.25	1
OD-SM1E-K55	39285	Wall mounting	IP55	0.25	1

### Stop buttons

Type	Product code	Design	Weight m [kg]	Package [pcs]
OD-SM1E-TL	39288	Stop button with arrestment (turn for unlock)	0.2	1
OD-SM1E-TLK	39289	Stop button with arrestment (unlocking by key <sup>1)</sup> )	0.2	1

<sup>1)</sup> Two keys are included in delivery.

### Locking inserts

Type	Product code	Weight m [kg]	Package [pcs]
OD-SM1E-UV	39290	0.1	1

### Push-button membranes

Type	Product code	Weight m [kg]	Package [pcs]
OD-SM1E-M	39291	0.012	1

### Dimensions

OD-SM1E-K41  
OD-SM1E-K55

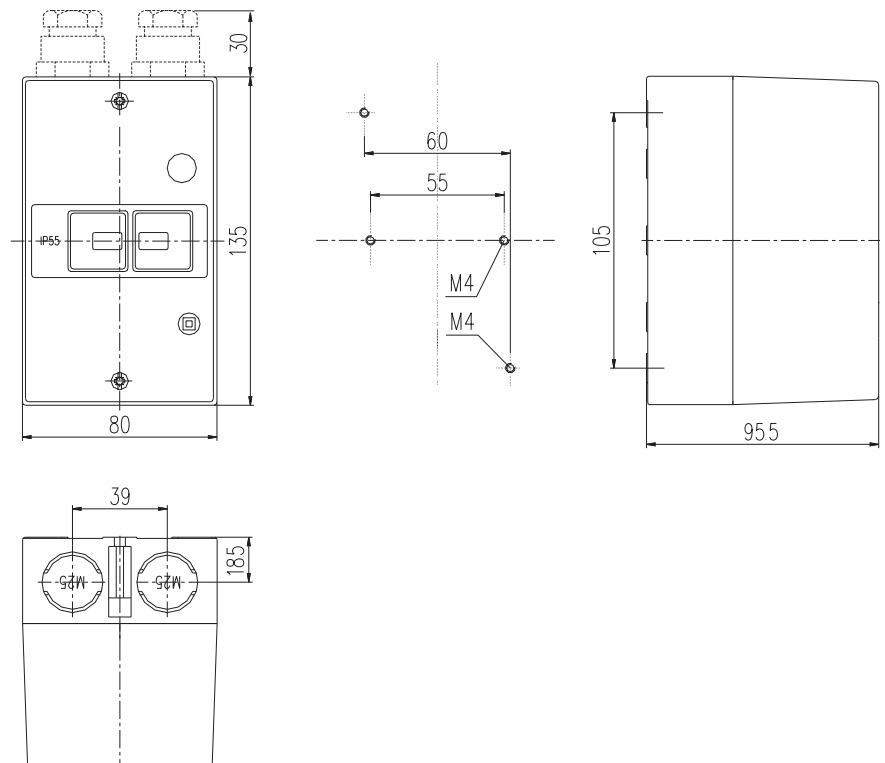

## INSULATING BOXES AND ACCESSORIES



### Indicator lights

- Accessory to: OD-SM1E-K., OD-SM1E-Z...
- It can serve for signalling of main contacts.
- Fixation in prepressed holes.

Type	Product code	Light indication colour	Rated voltage of the control circuit $U_c$ [V a.c.]	Weight m [kg]	Package [pcs]
<b>OD-SM1E-SE-A230</b>	39293	Green	230	0.01	1
<b>OD-SM1E-SE-A400</b>	39294	Green	400	0.01	1
<b>OD-SM1E-SG-A230</b>	39295	White	230	0.01	1
<b>OD-SM1E-SG-A400</b>	39296	White	400	0.01	1
<b>OD-SM1E-SC-A230</b>	39297	Red	230	0.01	1
<b>OD-SM1E-SC-A400</b>	39298	Red	400	0.01	1

### Specification

Type	OD-SM1E-S..	
Connection	cross-section	2x 0.5 mm <sup>2</sup>
	length	170 mm

### Operating conductor jumpers

- Accessory to: OD-SM1E-K., OD-SM1E-Z...
- For application of the insulating box in the five-wire system TN-S, it creates a joint of the neutral conductor N, cross-section of the connected conductor  $0.75 \div 4 \text{ mm}^2$ .

Type	Product code	Weight m [kg]	Package [pcs]
<b>OD-SM1E-NL</b>	39292	0.01	1



### Diagram

OD-SM1E-S..

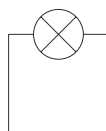

OD-SM1E-NL



### Plastic bushings

- Accessory to: OD-SM1E-K..
- They seal and fix inlet/outlet cable.
- One package contains 2 pieces of plastic bushings.

Type	Product code	Weight m [kg]	Package [[pcs]
<b>OD-SM1E-PV</b>	39282	0.015	1



**■ OEZ s.r.o.**

Šedivská 339  
561 51 Letohrad  
Czech Republic  
tel.: +420 465 672 379  
fax: +420 465 672 398  
e-mail: [oeztrade.cz@oez.com](mailto:oeztrade.cz@oez.com)  
[www.oez.com](http://www.oez.com)

**■ OEZ s.r.o.**

Trade Office Prague  
Podnikatelská 547  
190 11 Prague 9  
Czech Republic  
tel.: +420 257 181 710  
fax: +420 235 315 026  
e-mail: [oeztrade.cz@oez.com](mailto:oeztrade.cz@oez.com)  
[www.oez.com](http://www.oez.com)

**OEZ**®

[WWW.OEZ.COM](http://WWW.OEZ.COM)

Any changes reserved